

LAUFEN

- DE** Keramikspülkasten
- FR** Réservoir céramique
- IT** Cassetta di scarico in ceramica
- EN** Ceramic cistern
- ES** Cisterna cerámica
- NL** Keramische stortbak
- CS** Keramická splachovací nádržka
- LT** Keramikinis klozeto bakelis
- PL** Zbiornik wc do kompaktu ceramiczny
- HU** Kerámia öblítőtartály
- RU** Керамический сливной бачок
- BG** Керамично тоалетно казанче
- DA** Keramikcisterne
- SV** Porslincistern
- NO** Porselensisterne
- FI** keraaminen huuhtelusäiliö
- SK** Keramická splachovacia nádržka
- ZH** 陶瓷冲洗箱
- ET** Keraamilised loputuskastid
- HR** Keramička posuda za ispiranje
- LV** Keramikas skalojamā kaste
- PT** Caixa de autoclismo em cerâmica
- TR** Seramik rezervuar

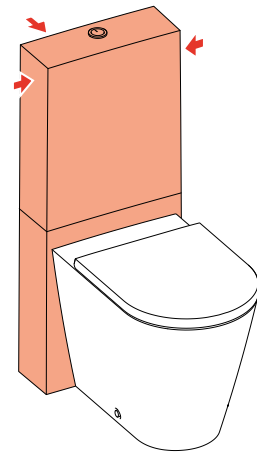

H829660

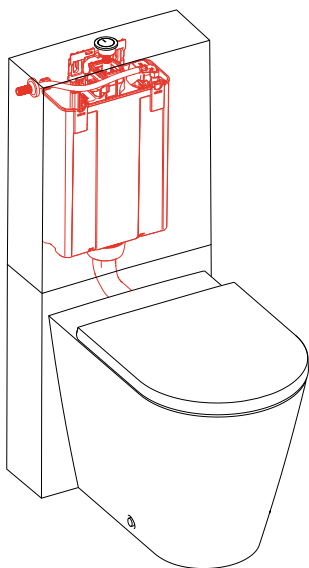

H829661

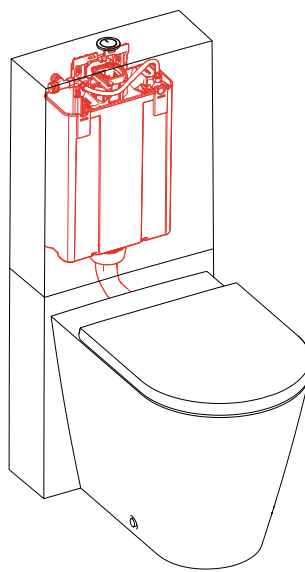

- DE** Diese Anleitung muss dem Benutzer ausgehändigt werden. Garantie/Haftung nur bei Montage gemäss Anleitung durch eine konzessionierte Fachkraft und gemäss örtlichen Vorschriften bei einem Druckbereich 0,5 – 10 bar.
- FR** Garantie/responsabilité uniquement assurées en cas de montage conforme au mode d'emploi, effectué par un spécialiste concessionnaire et en fonction des prescriptions locales dans des conditions de pression comprises entre 0,5 – 10 bars.
- IT** Garanzia/responsabilità assicurate soltanto in caso di montaggio conforme alle istruzioni per l'uso e eseguito da uno specialista concessionario in funzione delle prescrizioni locali con un campo di pressione di 0,5 – 10 bar.
- EN** Guarantee/Liability only when assembled by an approved specialist in accordance with the instructions and local regulations within the pressure range 0,5–10 bar.
- ES** Garantía/Responsabilidad sólo cuando está montado según las instrucciones de un profesional autorizado y de conformidad con la normativa local en el rango de presión 0,5 – 10 bar.
- NL** Garantie/aansprakelijkheid enkel bij montage volgens de handleiding door een bevoegde vakman en volgens de lokale voorschriften bij drukbereik 0,5 – 10 bar.
- CS** Garance/záruka pouze při montáži, prováděné dle návodu osobou odborně způsobilou s příslušnou koncesí a dle předpisů platných v místě a při tlaku v rozmezí od 0,5 do 10 barů.
- LT** Garantija / turintis atsakomybė suteikiama, jei montavimą pagal instrukciją atlieka kvalifikuotas specialistas pagal vietinius reikalavimus reikalavimus esant 0,5 – 10 barų slėgio diapazonui.
- PL** Gwarancja/odpowiedzialność prawna wyłącznie w przypadku montażu wykonanego przez upoważnionego specjalistę zgodnie z instrukcją oraz lokalnymi przepisami w zakresie ciśnienia od 0,5 do 10 bar.
- HU** Garancia/felelősség csak engedéllyel rendelkező szakember által végrehajtott, az útmutatásnak és a helyi előírásoknak megfelelő szerelés esetén, 0,5 – 10 baros nyomástartományban.
- RU** Гарантия действительна только в том случае, если монтаж выполнен специалистом согласно инструкции и с учетом местных предписаний при диапазоне давления 0,5 – 10 бар.
- BG** Гаранция / отговорност само при монтаж в съответствие с ръководството от лицензиран специалист и в съответствие с местните разпоредби за диапазон на налягането 0,5 – 10 бара.
- DA** Denne vejledning skal udleveres til brugeren. Garantien gælder kun, hvis monteringen udføres af en autoriseret fagmand, der følger vejledningen og overholder de lokale bestemmelser ved et tryk på 0,5 – 10 bar.
- SV** Denna anvisning måste överlämnas till användaren. Garanti/ersättningskyldighet gäller endast om monteringen har genomförts enligt anvisningen av en auktoriserad specialist och enligt de lokala föreskrifterna på tryckområdet 0,5 – 10 bar.
- NO** Denne veiledningen må utleveres til brukeren. Garanti/erstatningsansvar kun hvis monteringen er utført av en fagperson med konsesjon i henhold til veiledning og i samsvar med lokale forskrifter ved et trykk på 0,5 til 10 bar.
- FI** Tämä ohje täytyy antaa käyttäjälle. Takuu/tuotevastuu vain, kun asennuksen suorittaa toimiluvan omaava ammattilainen käyttöohjeen sekä paikallisten 0,5 – 10 baarin painealueetta koskevien määräysten mukaisesti.
- SK** Tento návod musí byť doručený používateľovi. Záruka platí, len ak sa montáž vykoná podľa návodu a ak ju vykoná odborník s oprávnením v súlade s miestnymi predpismi, a to pri rozsahu tlaku 0,5 – 10 bar.
- ZH** 必须将本说明书当面交给用户。保修/责任仅在遵照说明书，并由授权专业人员符合当地法规且在压力区间 0.5 - 10 bar 内操作时生效
- ET** See juhend tuleb kasutajale anda. Garantii kehtib ainult juhul, kui seade on paigaldatud kasutusjuhendi järgi, seda on teinud liitsentsiga spetsialist ning järgitud on kohalikke eeskirju ja paigaldatud on rõhuvahemikus 0,5–10 baari.
- HR** Ove se upute moraju predati korisniku. Garancija/odgovornost vrijedi samo ako je montažu izvršilo ovlašteno stručno osoblje prema uputama i lokalnim propisima pri rasponu tlaka od 0,5 do 10 bara.
- LV** Šīs instrukcijas ir jānodod lietotājam. Garantija ir spēkā tikai tad, ja licencēts speciālists uzstādīšanu veic atbilstoši vietējiem noteikumiem un 0,5–10 bar spiediena intervālā.
- PT** O presente manual deve ser entregue ao utilizador. Garantia/responsabilidade apenas no caso de montagem realizada por um técnico concessionado e segundo os regulamentos locais, com uma gama de pressão de 0,5 – 10 bar..
- TR** Bu kılavuz kullanciyı verilmelidir. Garanti/sorumluluk, sadece ürün 0,5 – 10 bar basınç aralığında kılavuzda öngörülen şekilde yetkili uzman personele tarafından ve yerel yönetmeliklerde öngörülügü şekilde monte edilginde geçerlilik kazanır.

DE/FR/IT/EN/ES/NL/CS/LT/PL/HU/RU/BG/DA/SV/NO/FI/SK/ZH/ET/HR/LV/PT/TR

Lieferumfang
 Contenu du colis
 Distinta dei pezzi
 Parts list
 Alcance del suministro

Toebehoren
 Rozsah dodávky
 Dalių sąrašas
 Zakres dostawy
 Szállítási terjedelem

Комплектация
 Список на деталите
 Leveringsomfang
 Leveransomfattning
 Leveranseomfang

Toimituskokonaisuus
 Obsah dodávky
 供货范围
 Osade nimekiri
 Popis dijelova

Daļu saraksts
 Lista de peças
 Parça listesi

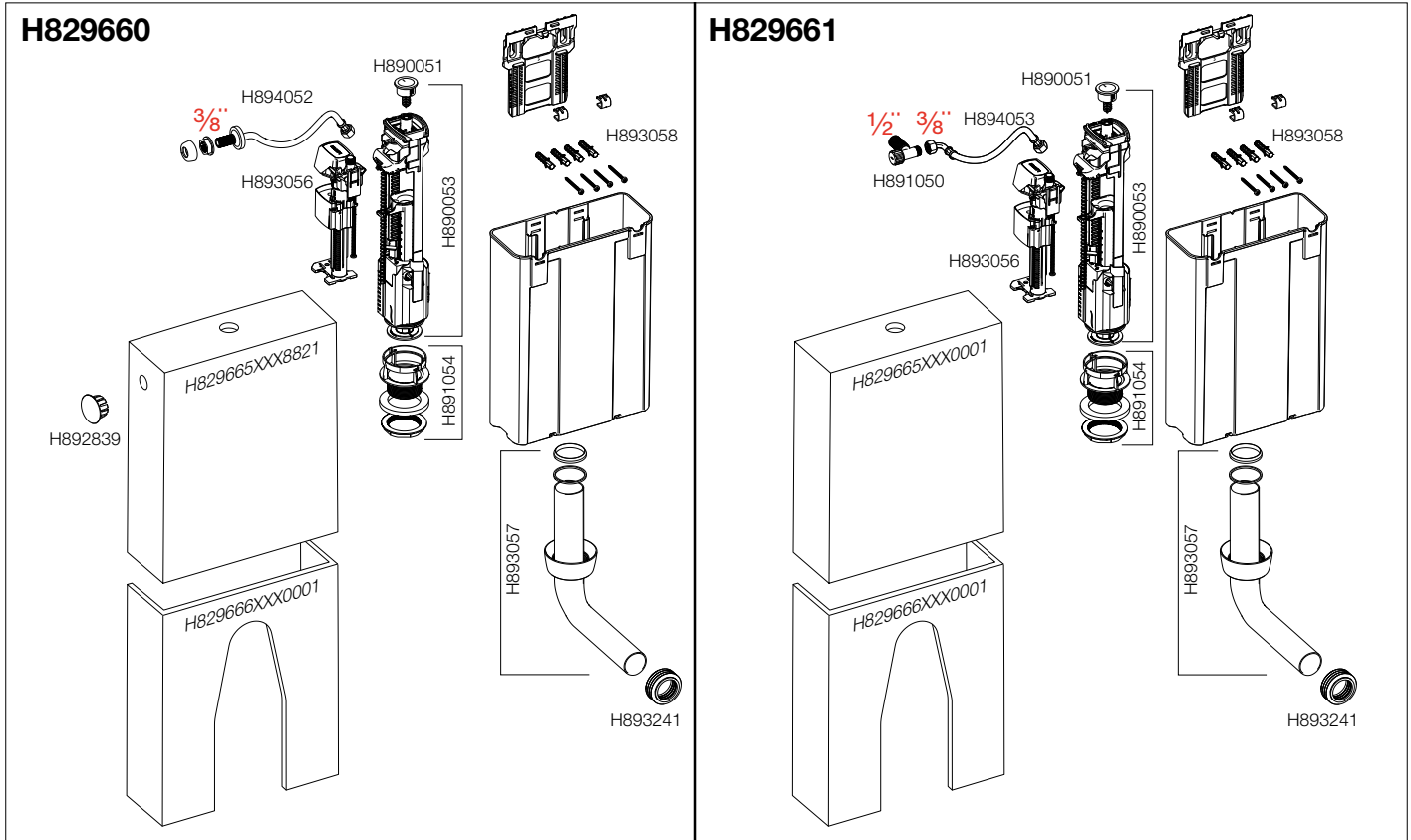

Dimensionen
 Dimensions
 Dimensiuni
 Dimensions
 Dimensiones

Afmetingen
 Rozměry
 Matmenys
 Wymiary
 Méretek

Размеры
 Размери
 Pakšalve
 Sāpa
 Grönsåpe

Suopa
 Rozmery
 规格
 Mootmed
 Dimenzije

Izmēri
 Dimensões
 Boyutlar

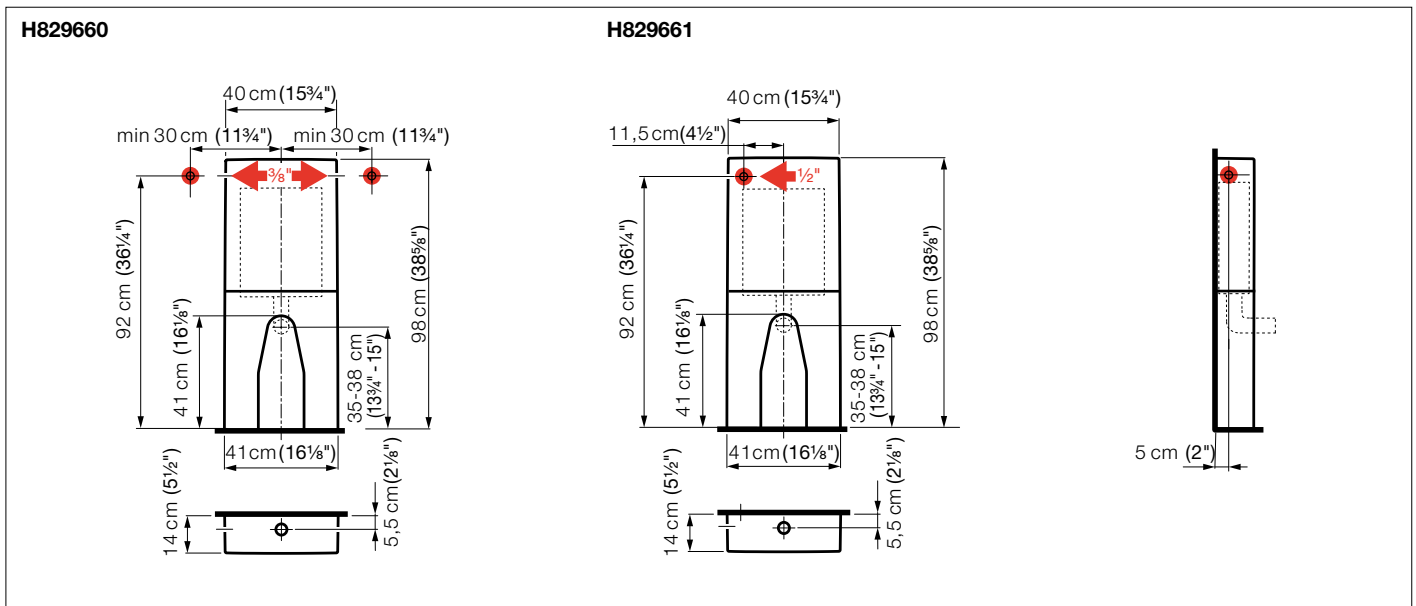

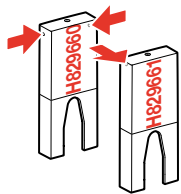

Montageablauf
Exécution du montage
Esecuzione del montaggio
Assembly procedure
Processo de montaje

Montageverloop
Průběh montáže
Montavimo tvarka
Odpyw montażowy
A szerelés menete

Последовательность монтажа
Протичане на монтажа
Monteringstrin
Monteringsprocedur
Monteringsbeskrivelse

Asennuksen
Montáž
装配程序
Kokkumonteerimine
Postupak montaže

Montāžas procedūra
Processo de montagem
Montaj prosedürü

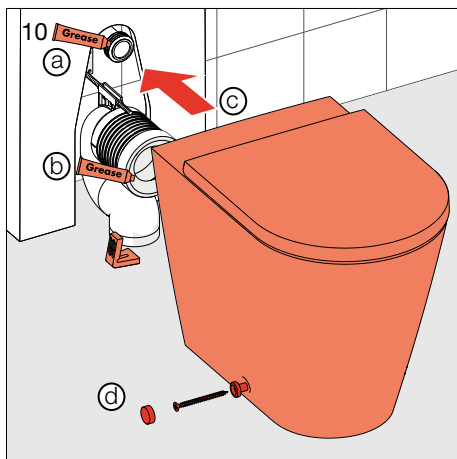
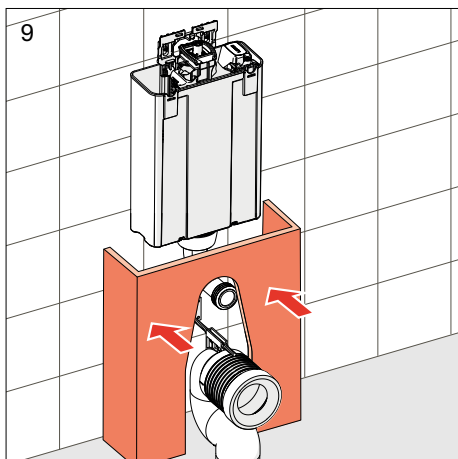
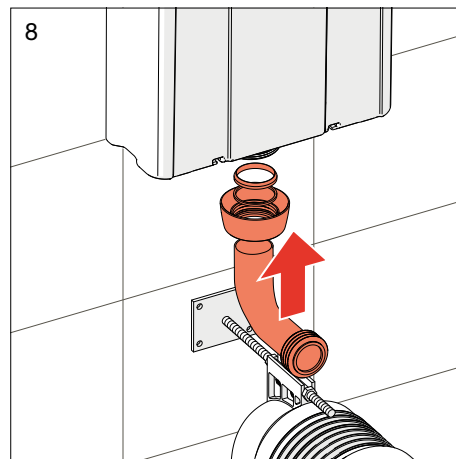
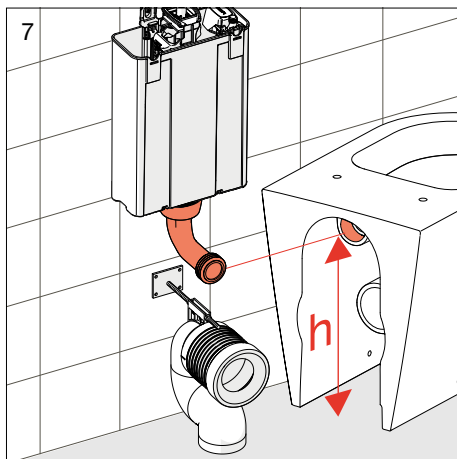
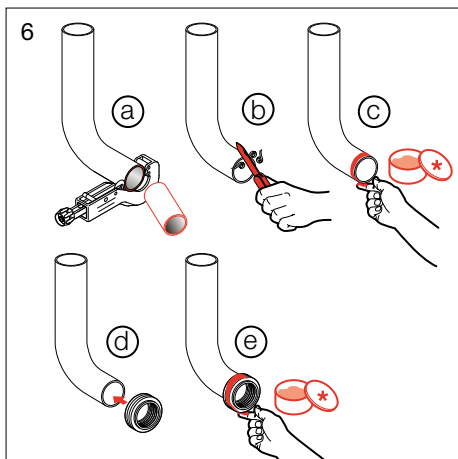
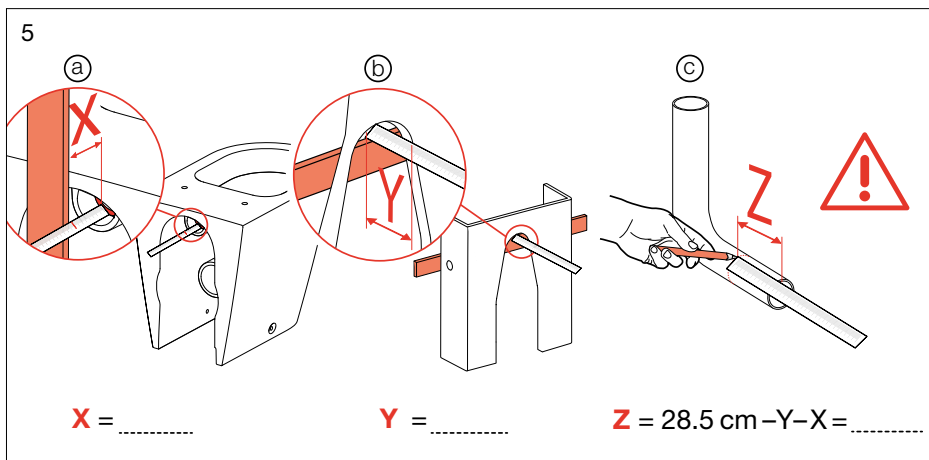
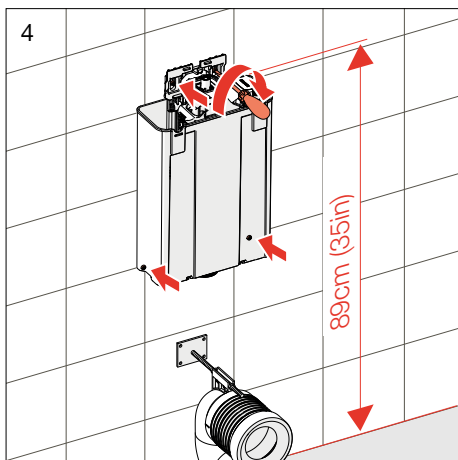
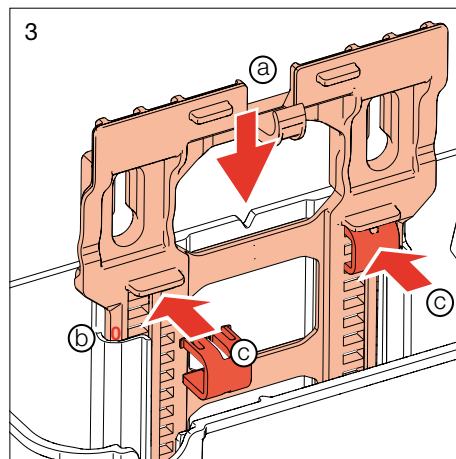
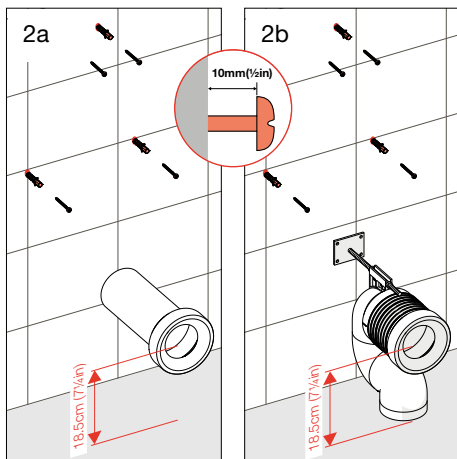
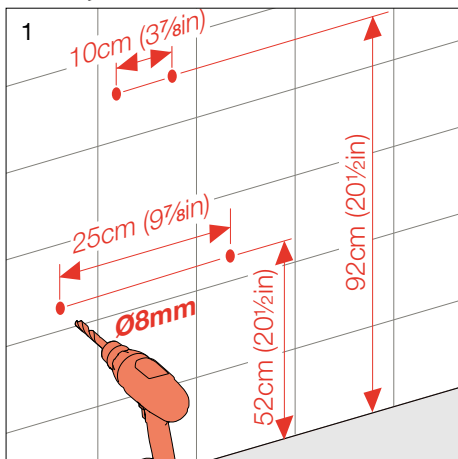

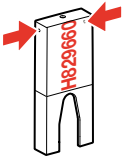

Montageablauf
 Exécution du montage
 Esecuzione del montaggio
 Assembly procedure
 Processo de montaje

Montageverloop
 Průběh montáže
 Montavimo tvarka
 Odplyw montażowy
 A szerelés menete

Последовательность монтажа
 Протичане на монтажа
 Monteringsstrin
 Monteringsprocedur
 Monteringsbeskrivelse

Asennuksen
 Montáž
 装配程序
 Kokkumonteerimine
 Postupak montaže

Montāžas procedūra
 Processo de montagem
 Montaj prosedürü

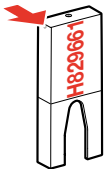
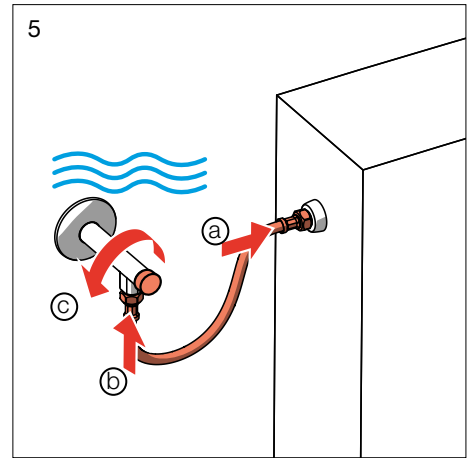
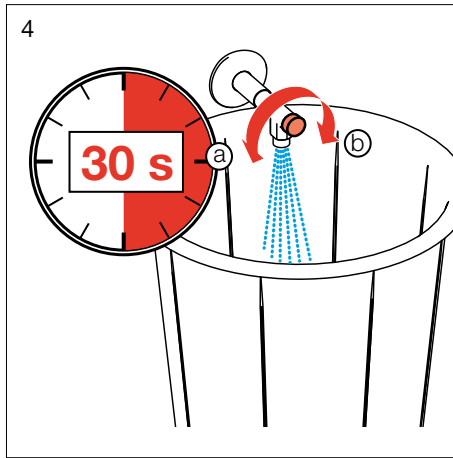
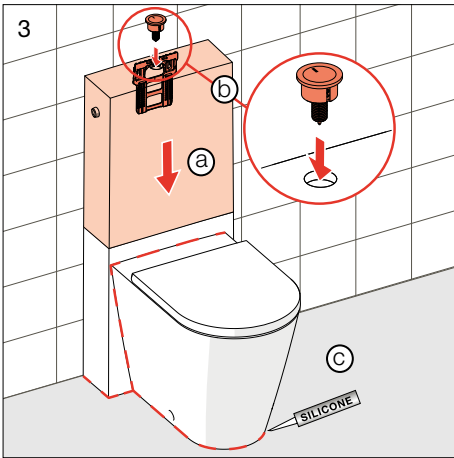
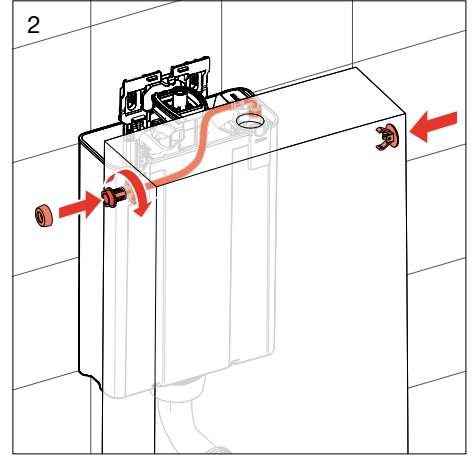
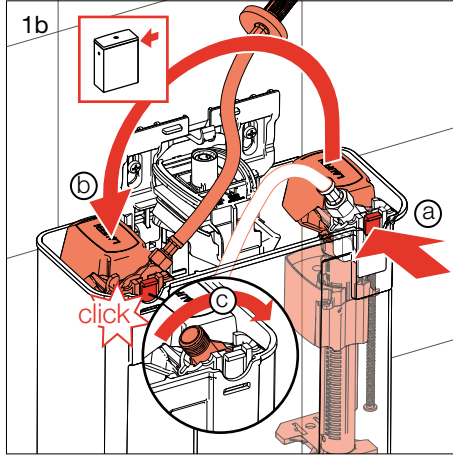
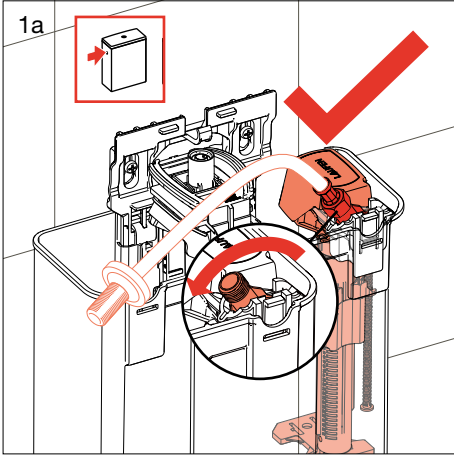

Montageablauf
 Exécution du montage
 Esecuzione del montaggio
 Assembly procedure
 Processo de montaje

Montageverloop
 Průběh montáže
 Montavimo tvarka
 Odplyw montażowy
 A szerelés menete

Последовательность монтажа
 Протичане на монтажа
 Monteringsstrin
 Monteringsprocedur
 Monteringsbeskrivelse

Asennuksen
 Montáž
 装配程序
 Kokkumonteerimine
 Postupak montaže

Montāžas procedūra
 Processo de montagem
 Montaj prosedürü

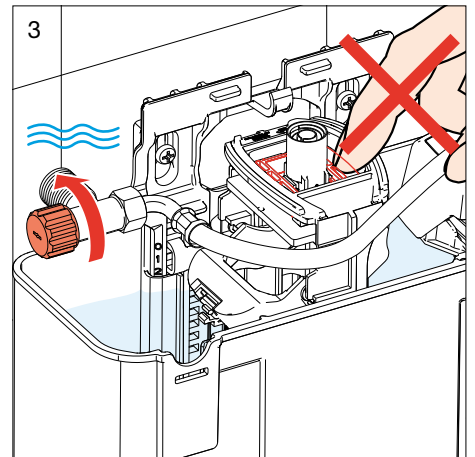
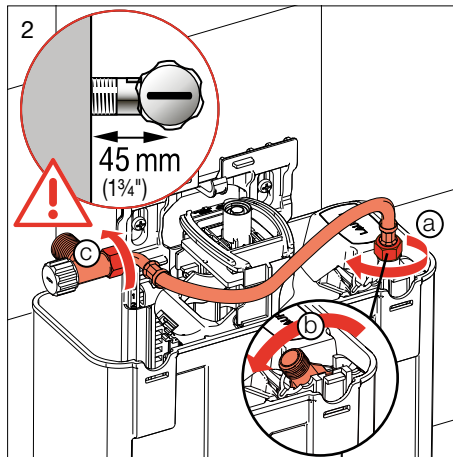
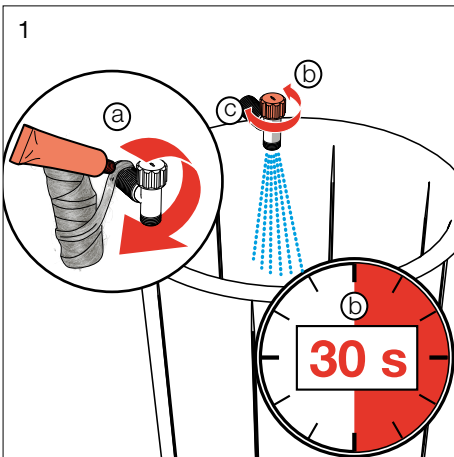

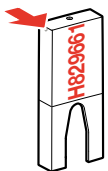

Montageablauf
Exécution du montage
Esecuzione del montaggio
Assembly procedure
Proceso de montaje

Montageverloop
Průběh montáže
Montavimo tvarka
Odplyw montażowy
A szerelés menete

Последовательность монтажа
Протичане на монтажа
Monteringstrin
Monteringsprocedur
Monteringsbeskrivelse

Asennuksen
Montáž
装配程序
Kokkumonteerimine
Postupak montaže

Montāžas procedūra
Processo de montagem
Montaj prosedürü

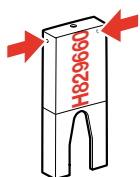
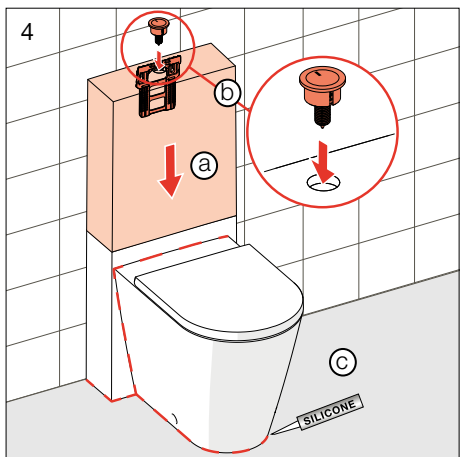

Service
Service
Servicio
Service
Servicio

Service
Servis
Aptarnavimas
Serwis
Karbantartás

Обслуживание
Обслужване
Service
Service
Service

Huolto
Servis
售后服务
Hooldus
Servis

Apkope
Assistència
Servis

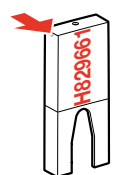
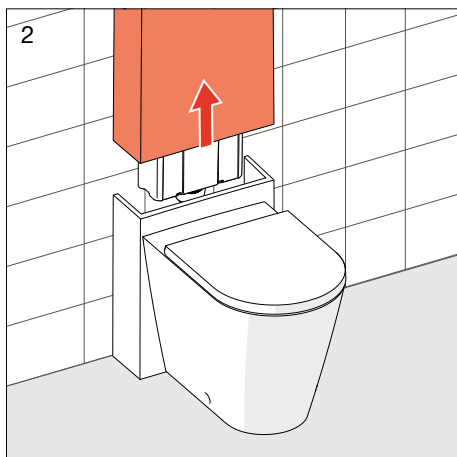
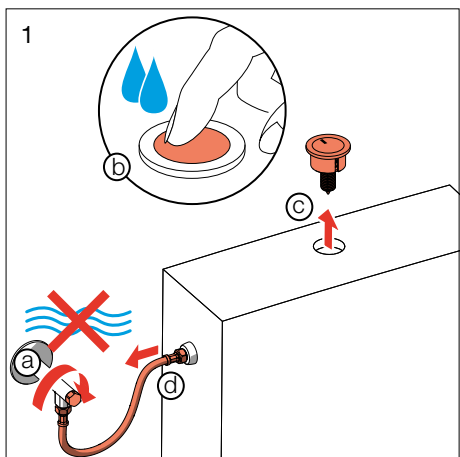

Service
Service
Servicio
Service
Servicio

Service
Servis
Aptarnavimas
Serwis
Karbantartás

Обслуживание
Обслужване
Service
Service
Service

Huolto
Servis
售后服务
Hooldus
Servis

Apkope
Assistència
Servis

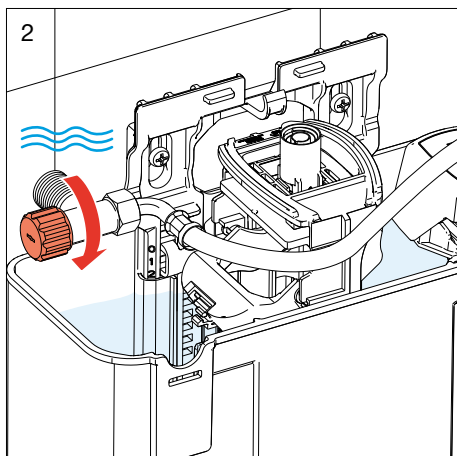
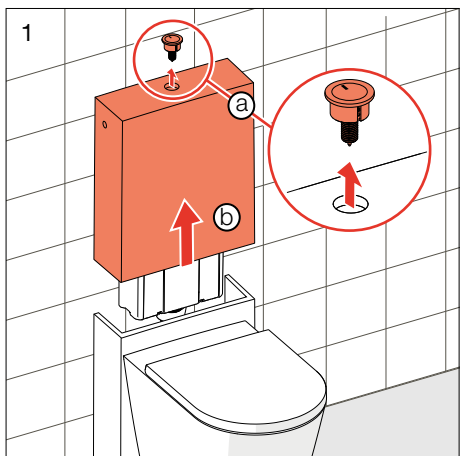
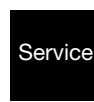

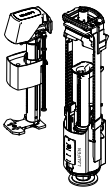

Service
Service
Servicio
Service
Servicio

Service
Servis
Aptarnavimas
Serwis
Karbantartās

Обслуживание
Обслужване
Service
Service
Service

Huolto
Servis
售后服务
Hooldus
Servis

Apkope
Assistència
Servis

Service

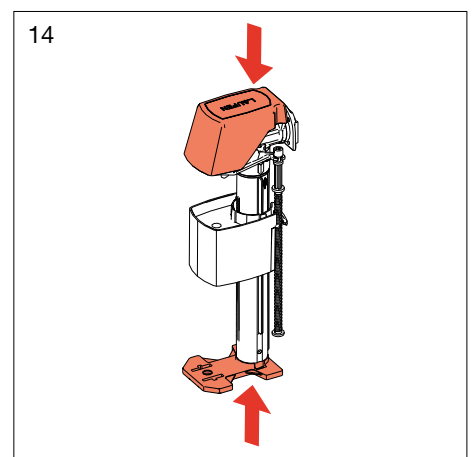
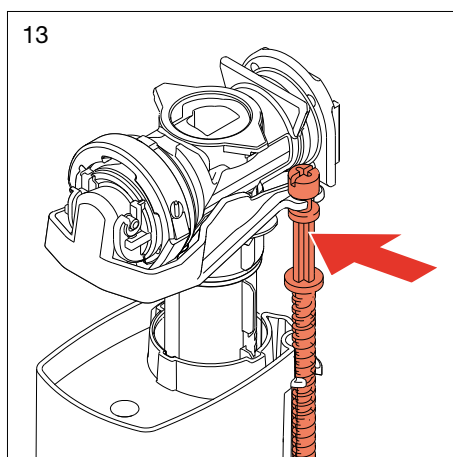
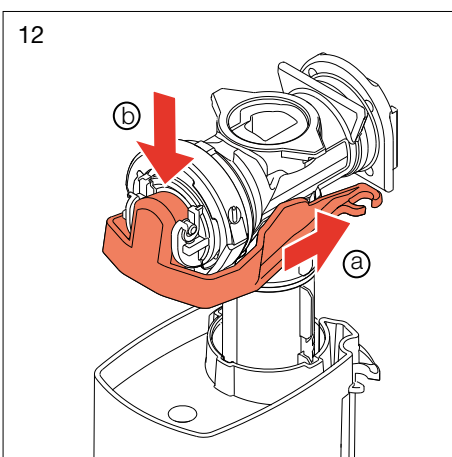
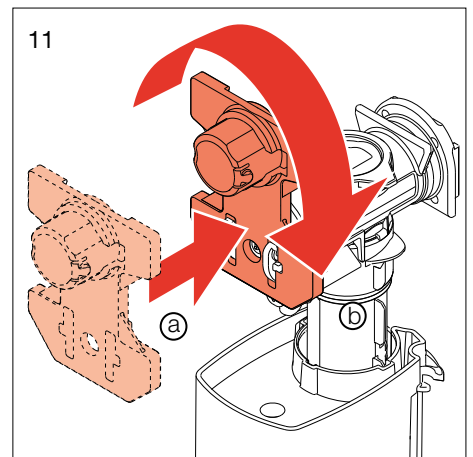
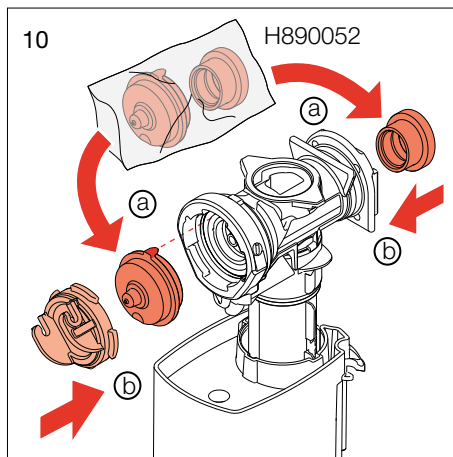
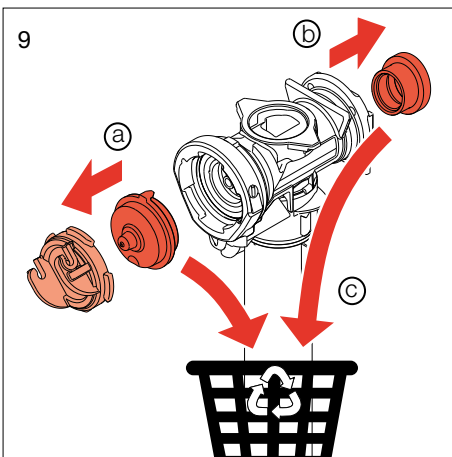
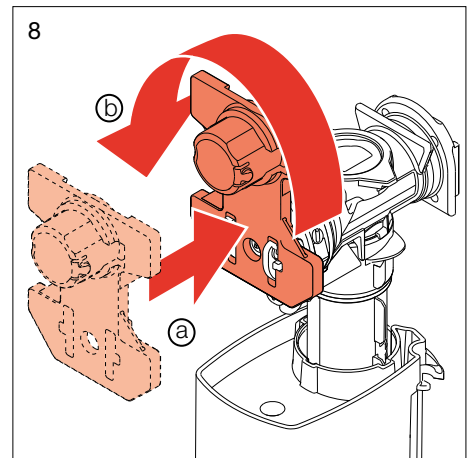
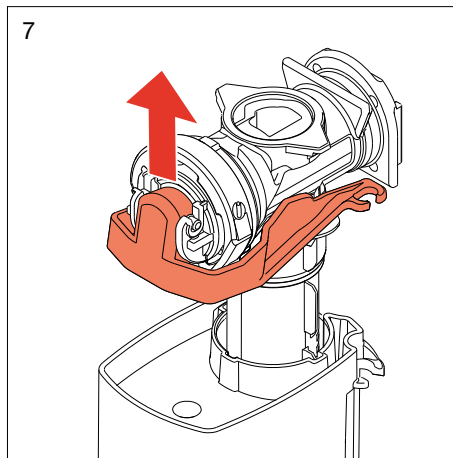
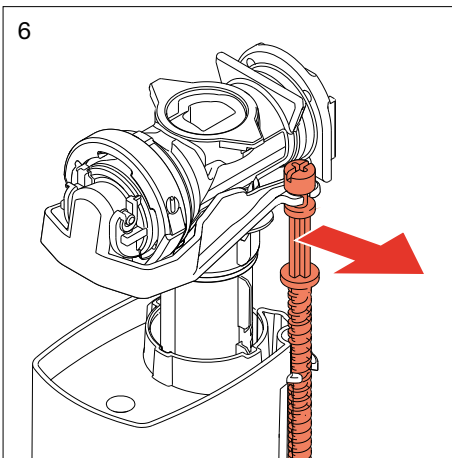
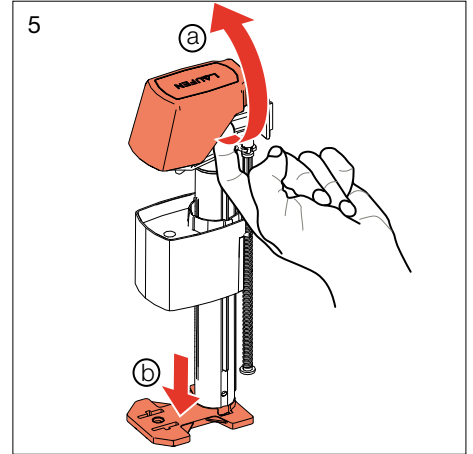
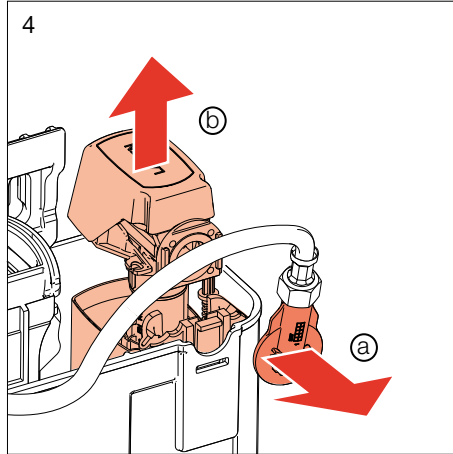
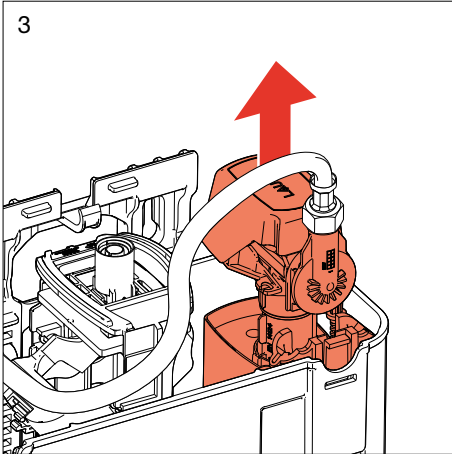

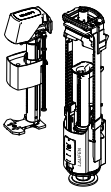

Service
Service
Servicio
Service
Servicio

Service
Servis
Aptarnavimas
Serwis
Karbantartās

Обслуживание
Обслужване
Service
Service
Service

Huolto
Servis
售后服务
Hooldus
Servis

Apkope
Assistència
Servis

Service

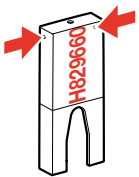
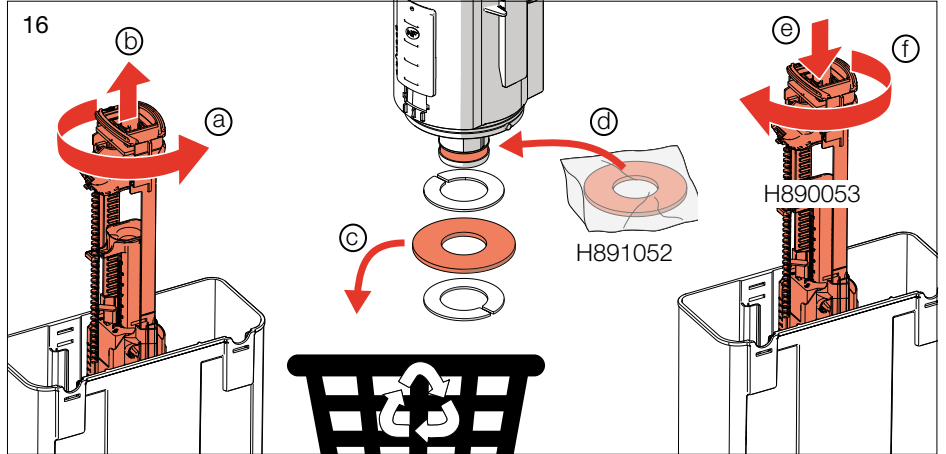
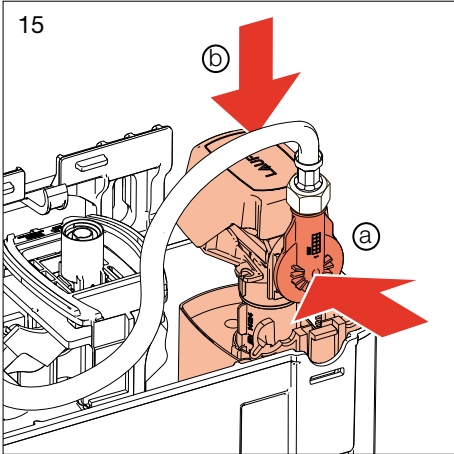

Service
Service
Servicio
Service
Servicio

Service
Servis
Aptarnavimas
Serwis
Karbantartās

Обслуживание
Обслужване
Service
Service
Service

Huolto
Servis
售后服务
Hooldus
Servis

Apkope
Assistència
Servis

Service

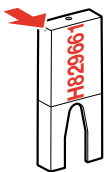
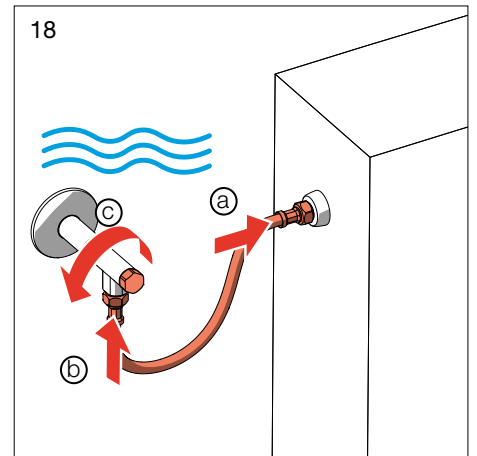
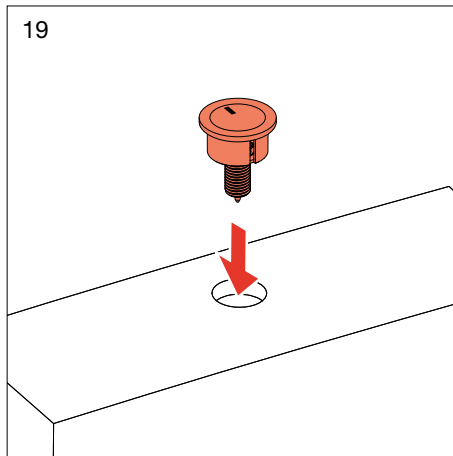
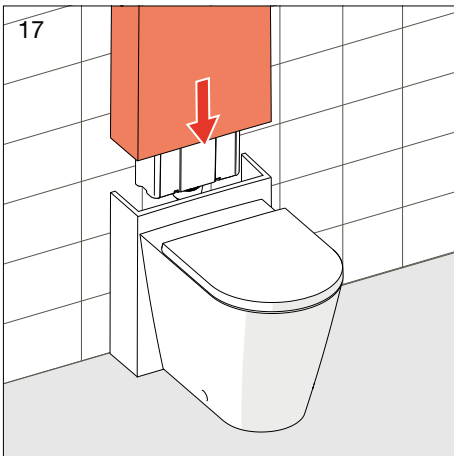

Service
Service
Servicio
Service
Servicio

Service
Servis
Aptarnavimas
Serwis
Karbantartās

Обслуживание
Обслужване
Service
Service
Service

Huolto
Servis
售后服务
Hooldus
Servis

Apkope
Assistència
Servis

Service

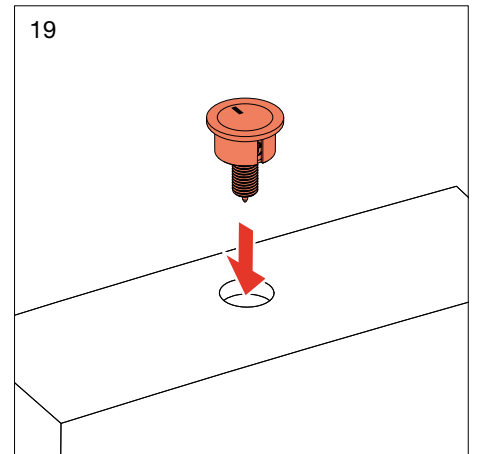
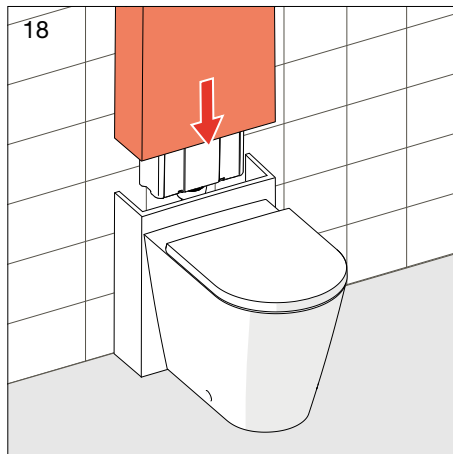
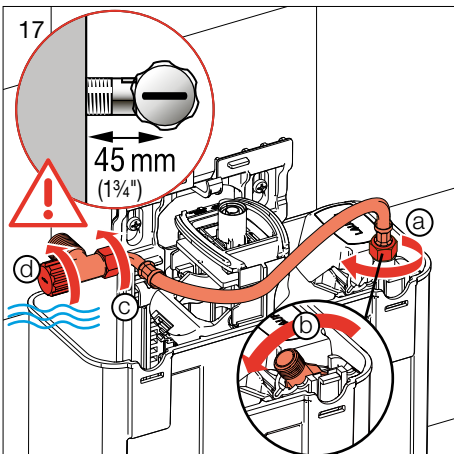

Verstellen der Spülmenge
 Réglage de la quantité d'eau de rinçage
 Modifica del volume di scarico
 Setting the flush volume
 Ajustar el tiempo de cantidad de lavado

Instellen van de spoelhoeveelheid
 Regulace splachovacího množství
 Plovimui naudojamo vandens kiekio reguliavimas
 Regulacja ilości płukania
 Öblítési mennyiség beállítása

Регулировка расхода воды для смыва
 Регулиране на количеството на промиване
 Justering af skyllevolume
 Ställa in flush volym
 Innstilling av spylemengde

Huhtelu asettaminen
 Prestavene množstva splachovanej vody
 调整冲洗量
 Loputuskoguse reguleerimine
 Postavljanje količine za ispiranje

Skalošanas daudzuma maiņa
 Regulação do volume de descarga
 Su bošaltma miktarinin ayarlanması



1

6/3L	4.5/3L
A/B	A/B
8/6	5/10

2

6/3L	4.5/3L
x(mm)	x(mm)
30	60

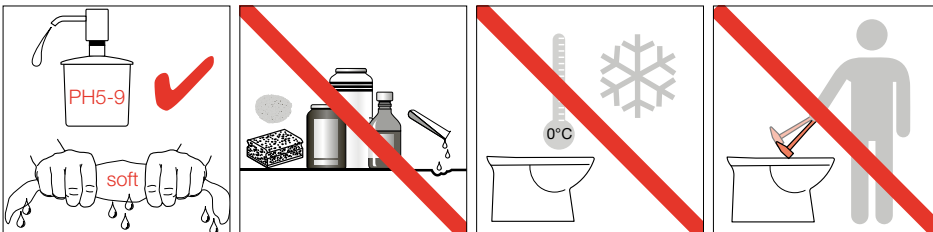

LAUFEN

Laufen Bathrooms AG
 Wahlenstrasse 46
 CH-4242 Laufen, Switzerland
 www.laufen.com