

# WC tablet holder for Prevista

## Instructions for Use

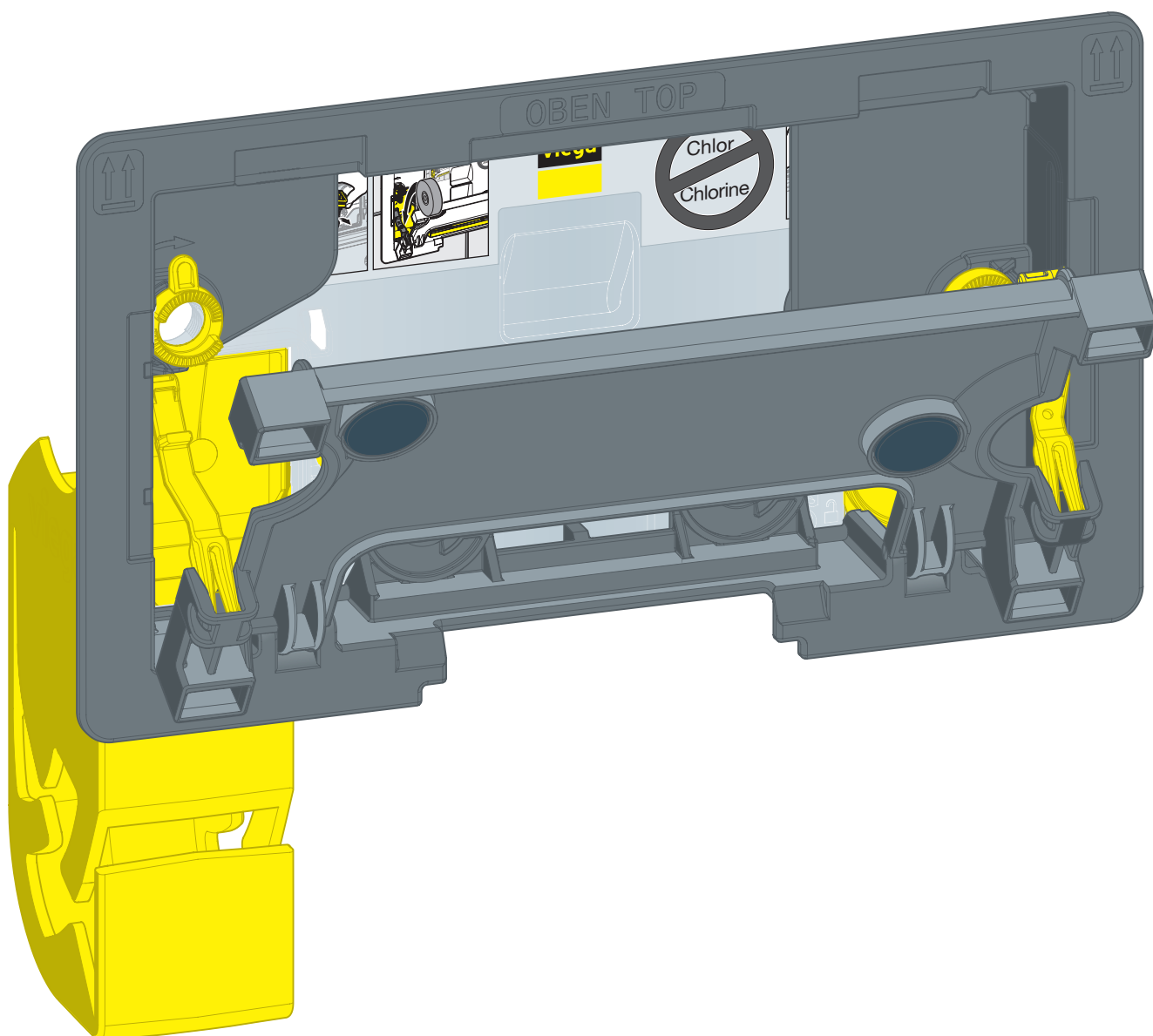

for WC cleaning blocks, concealed cisterns 3H, concealed cisterns 3L

**Model**  
8653.1

**Year built:**  
from 03/2019

en\_INT





# Table of contents

<b>1</b>	<b>About these instructions for use</b>	<b>4</b>
1.1	Target groups	4
1.2	Labelling of notes	4
1.3	About this translated version	5
<b>2</b>	<b>Product information</b>	<b>6</b>
2.1	Safety advice	6
2.2	Intended use	6
2.2.1	Areas of use	6
2.3	Product description	7
2.3.1	Overview	7
<b>3</b>	<b>Handling</b>	<b>8</b>
3.1	Assembly	8
3.1.1	Mounting the tablet holder	8
3.2	Use	12
3.2.1	Using the tablet holder	12
3.3	Disposal	13

# 1 About these instructions for use

Trade mark rights exist for this document; for further information, go to [viega.com/legal](http://viega.com/legal).

## 1.1 Target groups

The information in this instruction manual is directed at the following groups of people:

- Heating and sanitary professionals and trained personnel
- Operators
- Consumers

Individuals without the abovementioned training or qualification are not permitted to mount, install and, if required, maintain this product. This restriction does not extend to possible operating instructions.

The installation of Viega products must take place in accordance with the general rules of engineering and the Viega instructions for use.

## 1.2 Labelling of notes

Warning and advisory texts are set aside from the remainder of the text and are labelled with the relevant pictographs.

**DANGER!**

This symbol warns of possible life-threatening injury.

**WARNING!**

This symbol warns of possible serious injury.

**CAUTION!**

This symbol warns of possible injury.

**NOTICE!**

This symbol warns of possible damage to property.



*This symbol gives additional information and hints.*



### 1.3 About this translated version

This instruction for use contains important information about the choice of product or system, assembly and commissioning as well as intended use and, if required, maintenance measures. The information about the products, their properties and application technology are based on the current standards in Europe (e.g. EN) and/or in Germany (e.g. DIN/DVGW).

Some passages in the text may refer to technical codes in Europe/Germany. These should serve as recommendations in the absence of corresponding national regulations. The relevant national laws, standards, regulations, directives and other technical provisions take priority over the German/European directives specified in this manual: The information herein is not binding for other countries and regions; as said above, they should be understood as a recommendation.

## 2 Product information

### 2.1 Safety advice



**WARNING!**  
**Risk of malfunction of cardiac pacemakers and implanted defibrillators due to magnets**

The flush plate is fastened to the wall with magnets. Magnets may deteriorate or stop the functions of a cardiac pacemaker, defibrillator or similar implanted devices.

A defibrillator may stop working in the vicinity of magnets.

- If you wear this type of implanted device, keep a distance of at least 10 cm to the installed magnets.
- The operator must ensure that suitable measures have been taken (safety sign, for instance) warning wearers of such devices not to come too close to the installed magnets.

### 2.2 Intended use

#### 2.2.1 Areas of use

The WC tablet holder for Prevista is used to feed freshener blocks into the Prevista concealed cisterns.

The tablet holder is suitable for the concealed cisterns 3H and 3L.

The tablet holder is compatible with WC flush plates for Prevista.



**NOTICE!**  
**Chlorine and liquid cleaner may impair the function of the cistern.**

Do not use chlorine or liquid cleaner.

- Only use commercially available chlorine-free WC freshener blocks.

## 2.3 Product description

### 2.3.1 Overview

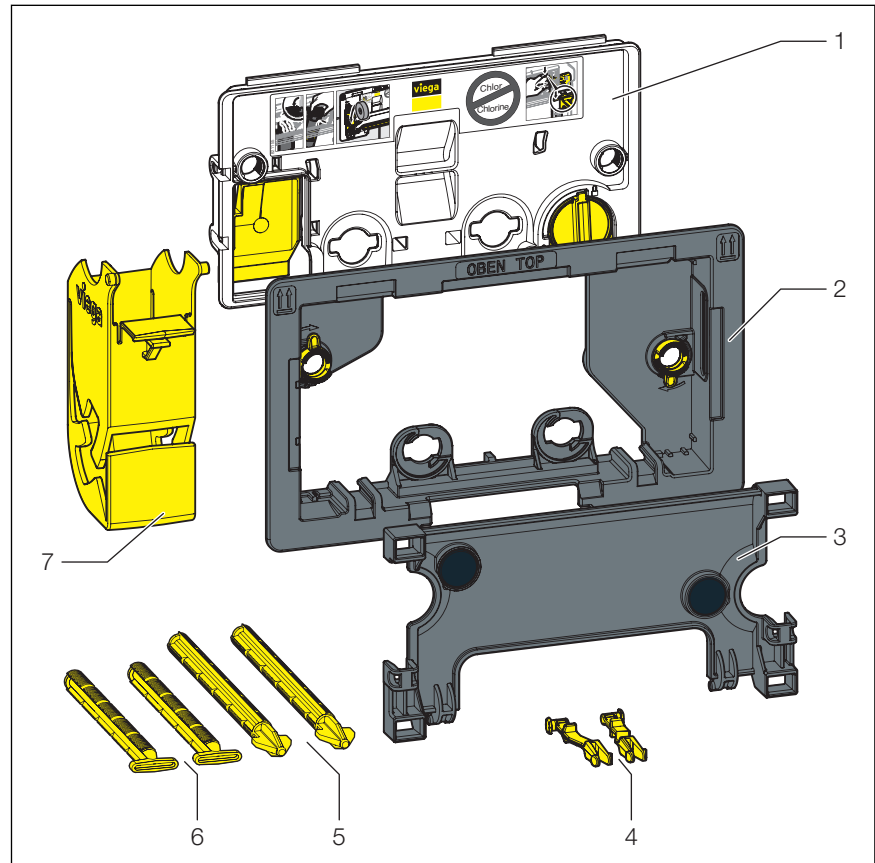

Fig. 1: Component overview

- 1 Cover plate
- 2 installation frame
- 3 holding panel
- 4 securing clips
- 5 actuating rods
- 6 retaining bolt
- 7 tablet holder

# 3 Handling

## 3.1 Assembly

### 3.1.1 Mounting the tablet holder

Requirements:

- The mechanism is placed on the cover plate.
  - For new installations: The cistern and flush actuation have been mounted.
  - For retrofitting: The existing base frame and flush plate have been removed. Retain the flush plate.
  - For electronic flush plates: Mount the control on the cover plate of the tablet holder.
- Clip the tablet holder into the cover plate.

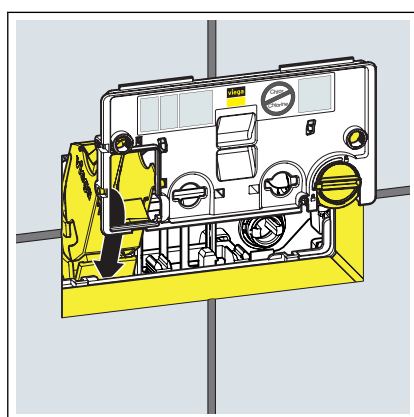
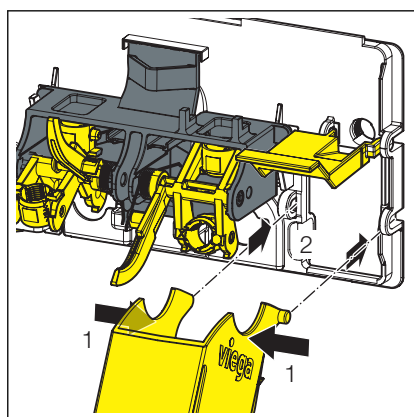

- Insert the tablet holder into the revision shaft.

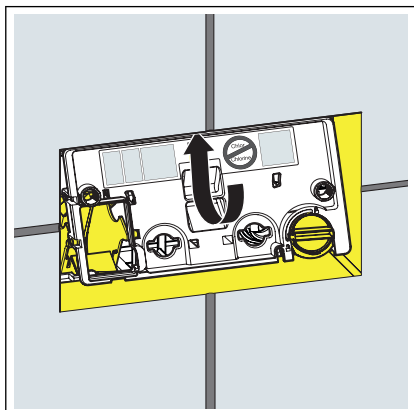

► Insert the cover plate all the way.

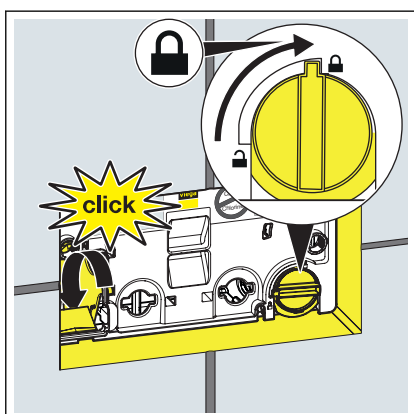

► Turn the cover plate lock by 90° in a clockwise direction.  
 ► Engage the tablet holder.

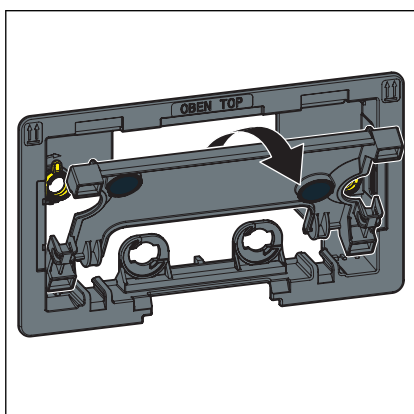

► Remove the top frame from the installation frame.

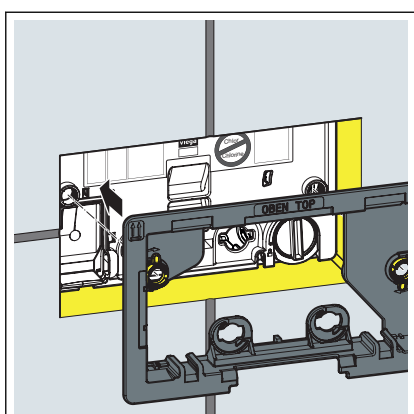

► Put on the installation frame.

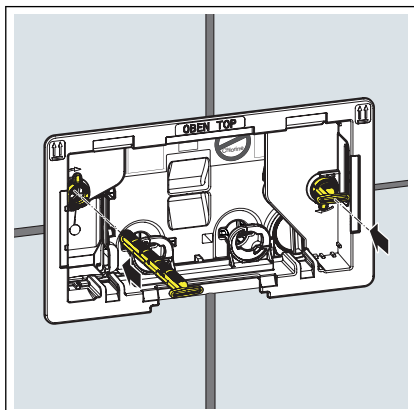

► Insert the retaining bolts.

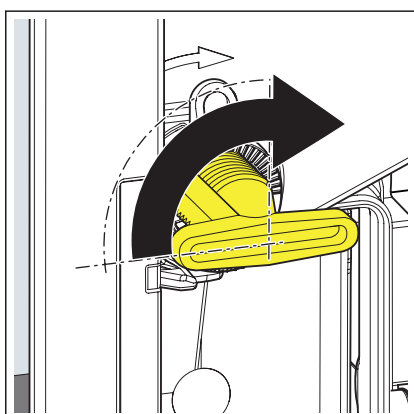

► Turn the retaining bolts by 90° in a clockwise direction.

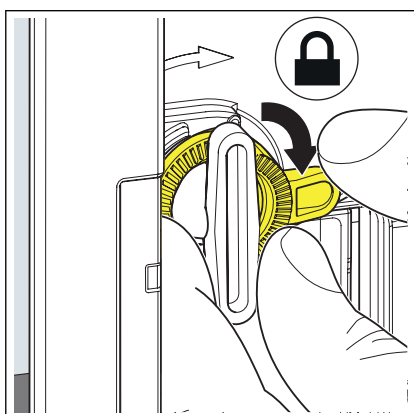

► To fix the retaining bolts, turn safety rings in a clockwise direction.

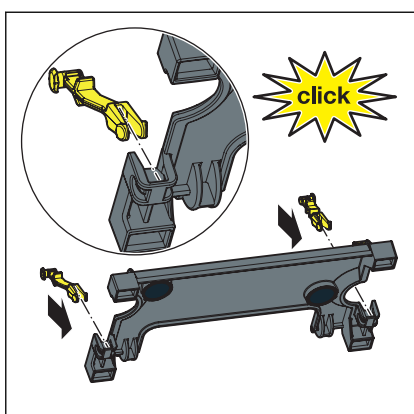

► Clip the safety clips into the top frame.

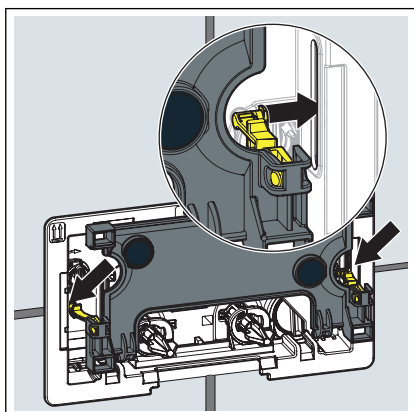

- ▶ Hook the safety clips into the installation frame.

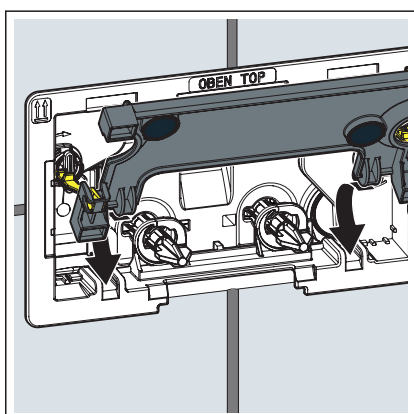

- ▶ Insert the top frame into the installation frame.
  - ⇒ The tablet holder has been installed. The flush plate can be mounted.

**INFO! Information for installation of the flush plate can be found in the associated instructions for use.**

## 3.2 Use

### 3.2.1 Using the tablet holder

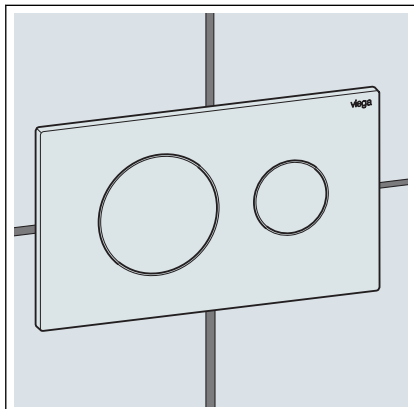

Requirements:

- The flush plate is mounted.

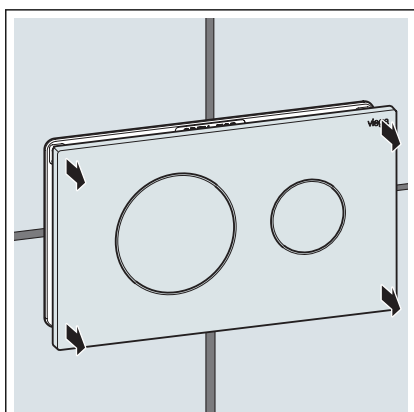

- Use both your hands to pull the flush plate forward to remove it.

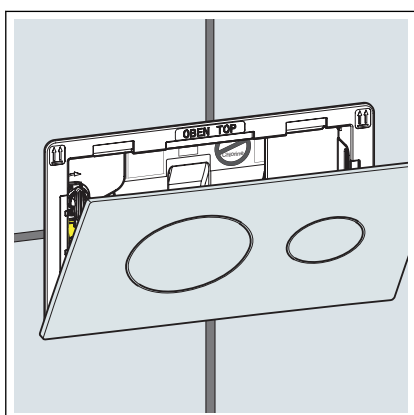

- Remove the flush plate.



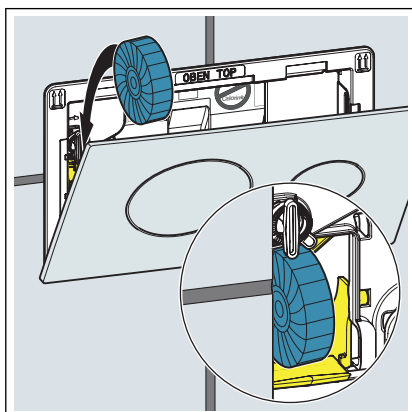

- Feed the freshener block into the tablet holder.

**NOTICE! Do not use liquid cleaner or chloric chemicals.**

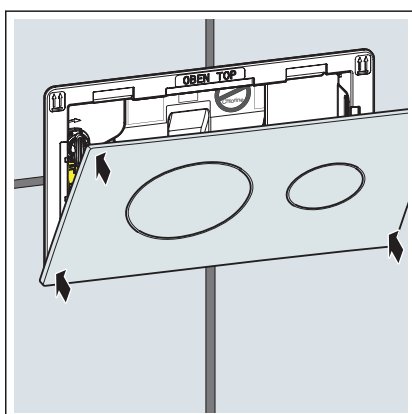

- Use both your hands to raise the flush plate.

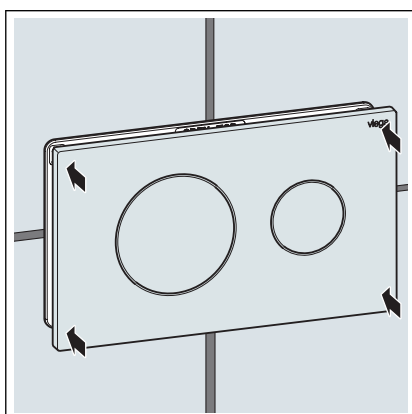

- Replace the flush plate.

### 3.3 Disposal

Separate the product and packaging materials (e. g. paper, metal, plastic or non-ferrous metals) and dispose of in accordance with valid national legal requirements.