

# LAUFEN

4.4745.1 / 4.4746.1 / 4.4747.1 / 4.4748.1  
4.4749.1 / 4.4750.1 / 4.4751.1 / 4.4752.1  
4.4753.1 / 4.4754.1 / 4.4755.1 / 4.4756.1  
4.4757.1

## frame 25



Garantie/Haftung nur bei Montage gemäss Anleitung.  
Responsabilité/garantie à condition d'observer les instructions de montage.  
Garanzia valida solo se si rispettano le istruzioni di montaggio  
The warranty/liability only applies when installation is effected as per the instructions.  
La garantía solamente será válida si se siguen las instrucciones de instalación.  
Garantie/aansprakelijkheid uitsluitend van kracht indien volgens de instructies is geïnstalleerd.  
Záruka a ručení za vady jsou poskytovány za podmínky, že montáž je provedena v souladu s tímto návodem.  
Garantija taikoma tik tuo atveju, kai montavimas yra atliktas tiksliai pagal instrukciją.  
Gwarancja obejmuje wyrób jedynie wówczas gdy montaż został przeprowadzony zgodnie z instrukcją.  
Szavatosság/jótállás csak az útmutató szerinti szerelés esetén.  
Мы предоставляем гарантию и несем ответственность, только если монтаж произведен в соответствии с инструкцией по монтажу.  
Гаранцията/отговорността е валидна само когато монтажът е изпълнен както е указано в инструкцията.

Lieferumfang  
Contenu du colis  
Distinta dei pezzi  
Parts list

Alcance del suministro  
Toebehoren  
Rozsah dodávky  
Dalių sąrašas

Zakres dostawy  
Szállítási terjedelem  
Комплектация  
Списък на детайлите

<b>Art.-No.:</b>	<b>B</b>
4.4745.1	450 mm
4.4746.1	550 mm
4.4747.1	600 mm
4.4748.1	650 mm
4.4749.1	800 mm
4.4750.1	900 mm
4.4751.1	1000 mm
4.4752.1	1200 mm
4.4753.1	1300 mm
4.4754.1	1500 mm
4.4755.1	1800 mm
4.4756.1	xxx mm

**Art.-No.: 4.4757.1**

**Art.-No.: 4.9071.3**



**DE** Arbeiten an den elektrischen Anlagen dürfen nur von autorisierten Fachleuten nach den örtlichen Vorschriften ausgeführt werden.

**FR** Seul un personnel qualifié agréé est autorisé à effectuer des travaux sur les installations électriques conformément aux prescriptions locales.

**IT** Ogni tipo di intervento sugli impianti elettrici può essere eseguito esclusivamente da personale esperto che operi in conformità con le vigenti normative locali.

**EN** Work on electrical equipment may be performed only by authorized electricians according to local regulations.

**ES** Sólo el personal especializado y autorizado puede realizar los trabajos en las instalaciones eléctricas cumpliendo las prescripciones locales.

**NL** Werkzaamheden aan de elektrische installaties mogen uitsluitend door geautoriseerde vaklui volgens de plaatselijke voorschriften worden uitgevoerd.

**CS** Práce na elektrických zařízeních smíjí být prováděny jen oprávněnými odborníky v souladu s místními předpisy.

**LT** Darbus su elektros įranga, laikantis vietinių reikalavimų, leidžiama atlikti tik autorizuotiems specialistams.

**PL** Prace przy urządzeniach elektrycznych mogą być wykonywane tylko przez wykwalifikowany personel i zgodnie z miejscowymi przepisami.







**HU** Elektromos berendezéseken bármilyen munkát kizárólag arra feljogosított szakember végezhet a helyi előírásoknak megfelelően!

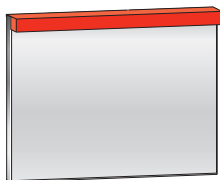





**RU** Работы над электрооборудованием разрешается производить только авторизованным на это специалистам, в соответствии с местными правилами.

**BG** Работите на електрическите уреди могат да бъдат изпълнени само от авторизираните специалисти, според локалните предписания.









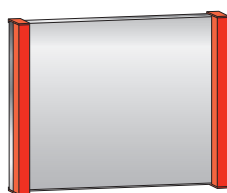
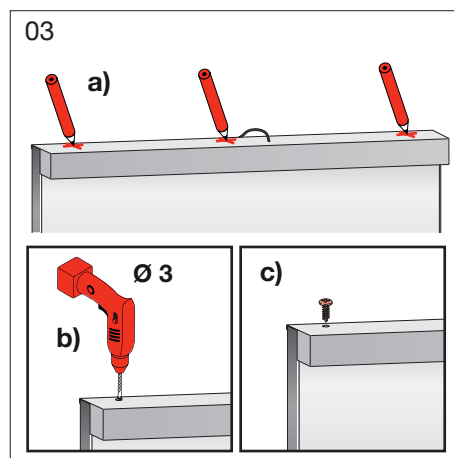
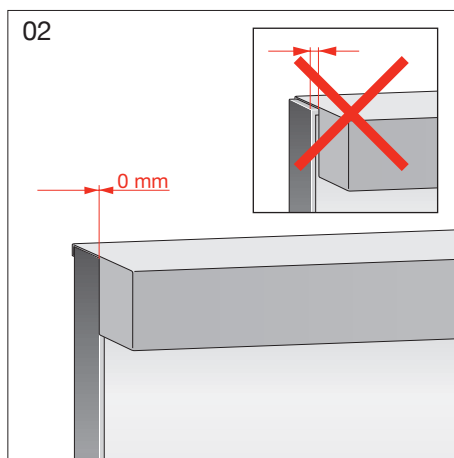
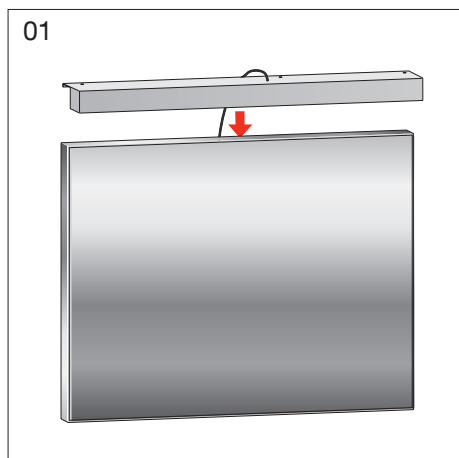







 Montageablauf  
 Exécution du montage  
 Esecuzione del montaggio  
 Assembly procedure  
 Proceso de montaje  
 Montageverloop

 Průběh montáže  
 Montavimo tvarka Odplyw  
 Odplyw montażowy  
 A szerelés menete  
 Последовательность монтажа  
 Протичане на монтажа



 Montageablauf  
 Exécution du montage  
 Esecuzione del montaggio  
 Assembly procedure  
 Proceso de montaje  
 Montageverloop

 Průběh montáže  
 Montavimo tvarka Odplyw  
 Odplyw montażowy  
 A szerelés menete  
 Последовательность монтажа  
 Протичане на монтажа

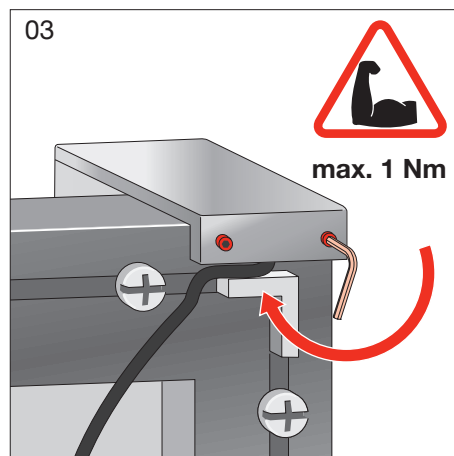
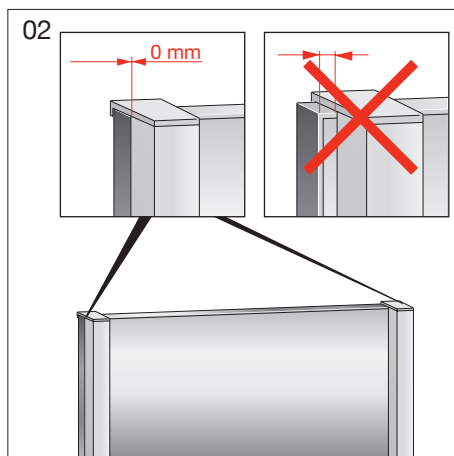
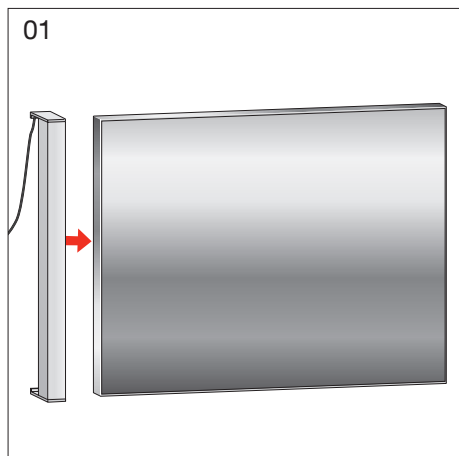

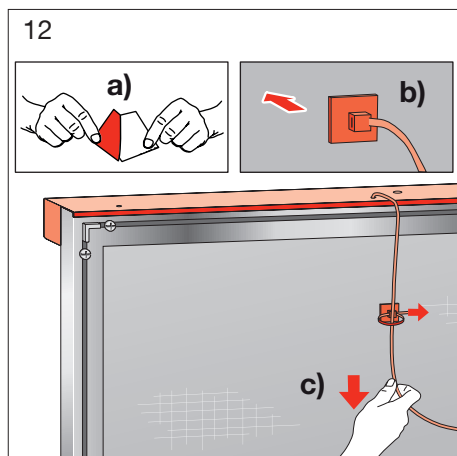
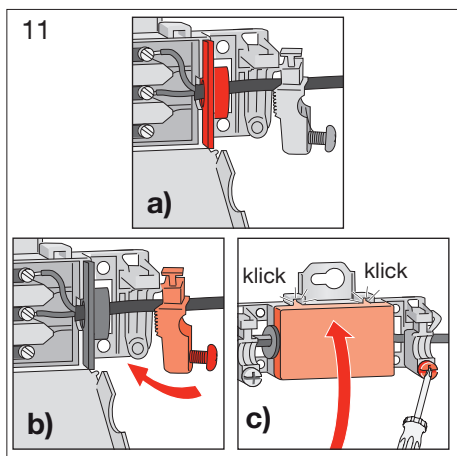
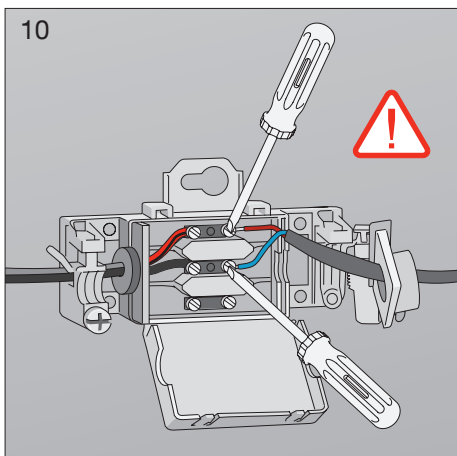
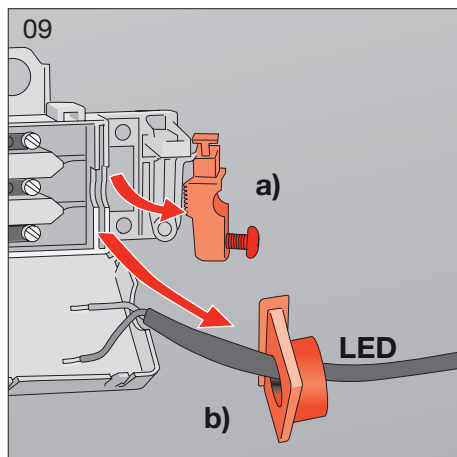
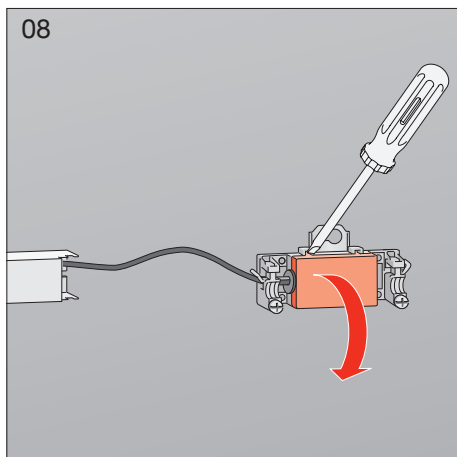
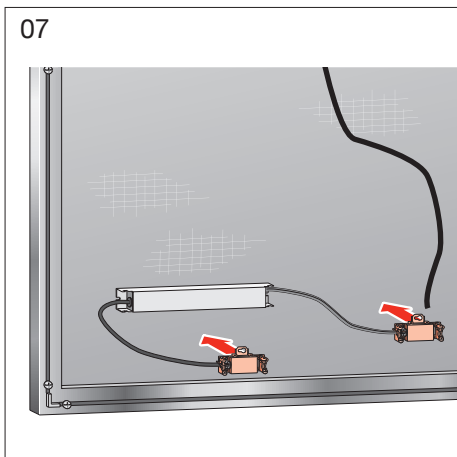
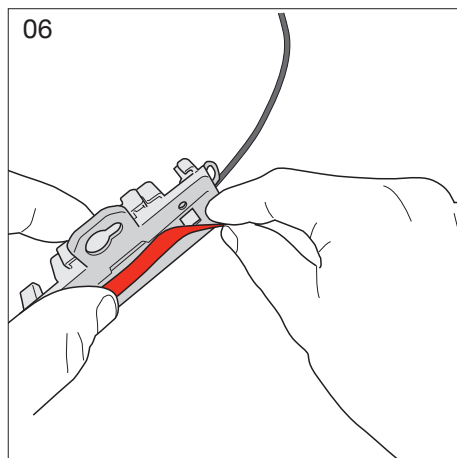
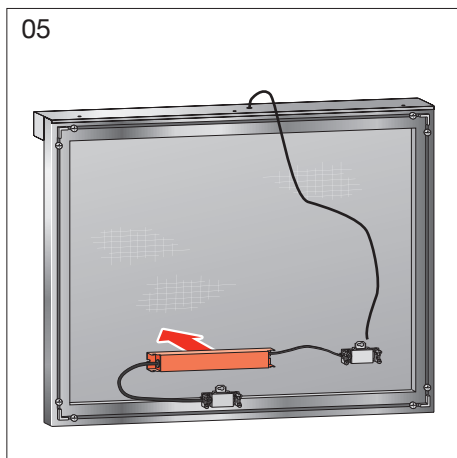
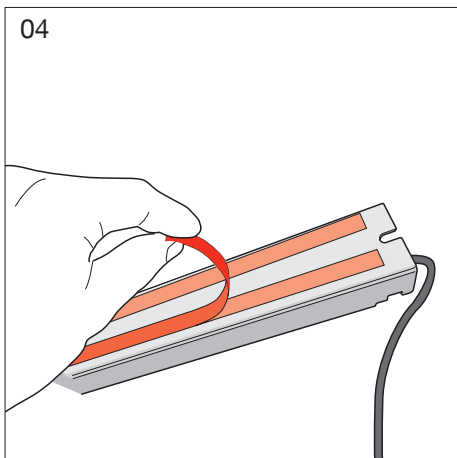

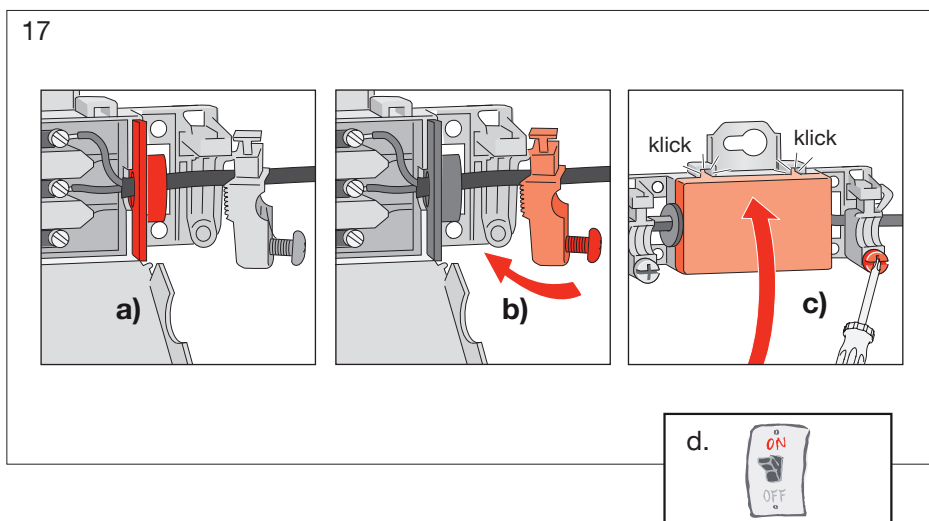
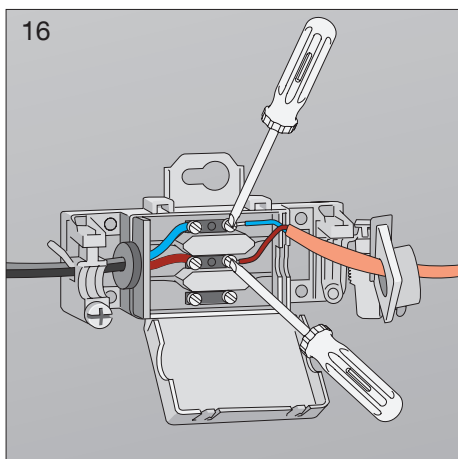
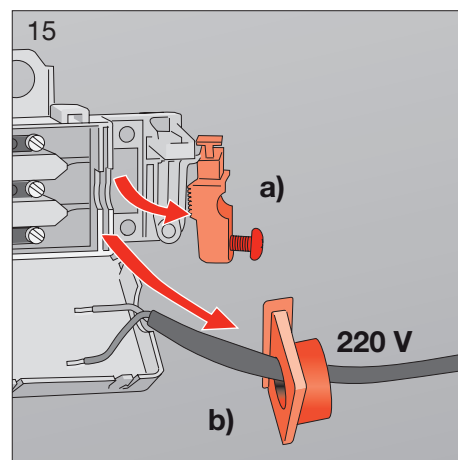
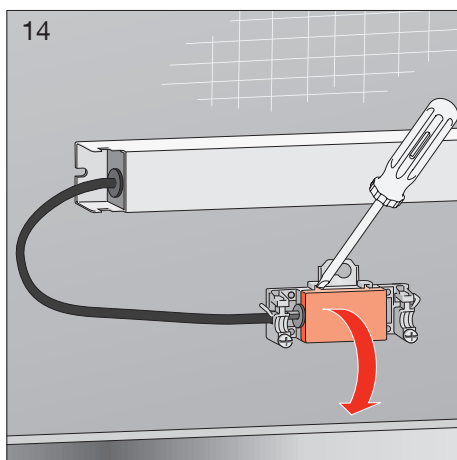
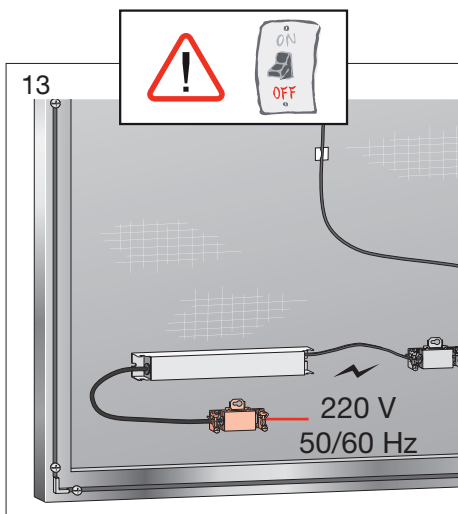

# LAUFEN

Laufen Bathrooms AG  
Wahlenstrasse 46  
CH-4242 Laufen, Switzerland  
www.laufen.com

DE/FR/IT/EN/ES/NL/CS/LT/PL/HU/RU/BG